



Series 7650 Installation Instructions
Sliding Glass Door

Removal of Old Fenestration Products

Ensure any old fenestration products are removed and properly disposed. You may be able to recycle or donate removed glass and frames. For more information, check with your local recycling agency, the American Architectural Manufacturers Association (AAMA), the US Environmental Protection Agency (at www.epa.gov/recycle) or the Building Materials Reuse Association website to locate a nearby company or organization that accepts used windows and doors. To donate removed products, contact local nonprofits in need of building supplies, such as Habitat for Humanity.

Please note: Homes and condominiums built before 1978 may have lead-based paint which can pose serious health hazards during removal. Information and instruction regarding proper management of lead paint is available at www.epa.gov/lead.

Installation Preparation

Sliding doors are custom manufactured specific to each application. Prior to installation it is important that you carefully review and understand the installation instructions and any drawings supplied. Western Window Systems' fenestration products should only be installed by experienced and qualified installation professionals. Failure to follow these instructions may result in poor performance including, but not limited to, operation, security, and weatherproofing and may void Western Window Systems' express limited warranties.

Product Handling and Storage

This is a finished product that must be protected before, during, and after installation to prevent damage to the glass, frame, finish, and hardware. The flush and water barrier sill tracks are supplied with individual track protectors that should be removed prior to assembly and installation of the frames. Upon completion of door installation, the track protectors can be selectively cut to length and re-installed to allow for specific panel operation or no panel operation.

Door panels should be stored in a dry location that is protected from the elements. Wet packaging can cause damage to product finishes. If the packaging becomes wet immediately replace it with dry packaging. Door panels should be stored and transported upside down and should not be dropped or dragged from the delivery truck to avoid damage to the bottom rail extension.

Components

The components supplied will vary depending on the configuration you are installing. Before proceeding with the installation, inspect the components to become familiar with them and confirm that there is no damage that will affect the appearance or performance of the installed product. Damaged or missing parts should be reported to your supplier immediately. If screens are included they will be installed in a similar fashion as the glass panels.

Frame components: Each door will have a Head Track Assembly, Threshold Track Assembly, Lock Jamb, and Fixed Jamb.

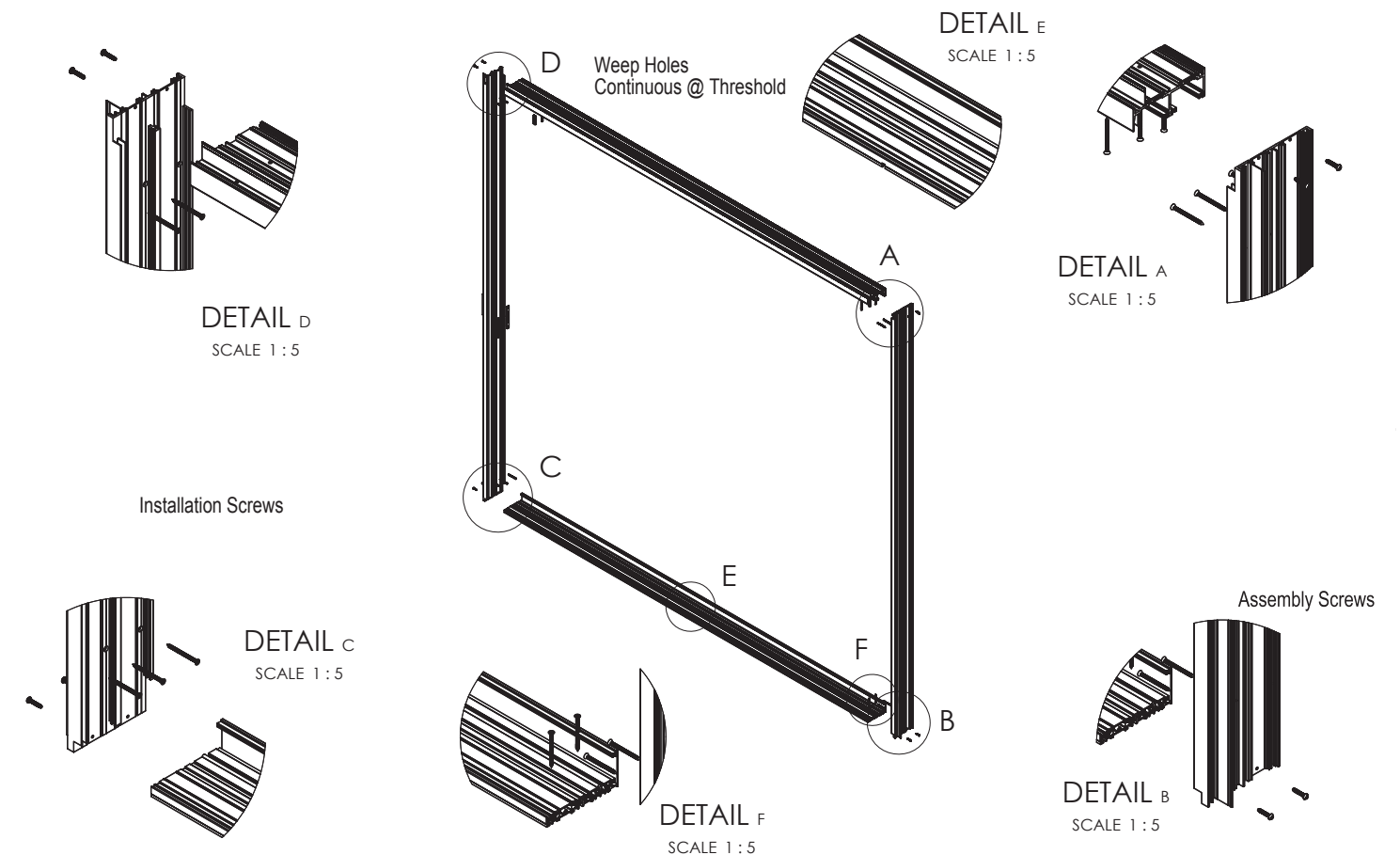

Vent Panel components: The number of vent panels will depend on the configuration of the door you are installing. Each Vent Panel Assembly will include a Top Rail, Vent Bottom Rail, Lock Stile, Vent Interlock, Handle Set, and height adjustable Tandem Rollers.

Fixed Panel components: The number of fixed panels will depend on the configuration of the door you are installing. Each Fixed Panel Assembly will include a Fixed Top Rail, Fixed Interlock, Fixed Stile, and Fixed Bottom Rail.

Dead-Lite Panel: The Dead-Lite Panel will consist of a Fixed Top Rail, Fixed Stiles, False Jamb, and Fixed Bottom Rail.

Other Tools and Products Necessary for Installation

- flashing membrane
- sealant
- plastic block
- non-marring mallet
- #10 x 2 1/2" flat-head screws
- #8 x 1 1/4" self-tapping oval head screws
- #10 x 1 1/4" pan-head screws (eight (8) per frame – a pair for each corner).

Frame Installation

Configurations: XO, OX or OXXO .1-11 OXOL or OXOR .1-11 & A XO0 or OOX .1-11 & B

For ease of installation, production labels will be marked (F) for Fixed Panel Assembly and (V) for Vent Panel Assembly.

1. Refer to the drawings supplied and inspect the rough opening carefully to verify that it's been prepared correctly to accept the configuration and size you are installing, including ensuring the opening is plumb, level, and approximately 1/2" wider and 1/4" taller than the net frame size.
2. Rough opening must be waterproofed in accordance with AAMA Installation Masters standards, flashing and sealant manufacturer instructions, and meet all local building codes. If the floor condition is wood, it must be protected with an appropriate flashing or waterproofing material prior to door frame installation.
3. Assemble the members of the main frame on the floor. Protect to avoid damaging finish. Use a pair of #10 x 1 1/4" pan-head screws per corner. If frame has an optional fin, install the frame assembly into the flashed opening, apply and seal the provided continuous corner bridges.
4. Underneath the Threshold Track, apply a full bead of quality sealant where the Jambs and Threshold Track meet. From the topside of the Threshold Track, seal the vertical joint where the interior leg of the Threshold Tracks meets the Jamb at 90 degrees. Tool the sealant into both areas to ensure the seal is complete.
5. Center the Frame in the opening and temporarily shim the Jambs. If the floor is not level, shim the Threshold Track as required.
6. After dry fitting the frame, clean the floor and apply a heavy bed of sealant from Jamb to Jamb on the interior side of the installation holes. At the Jambs, the sealant should run vertical (approximately 6") on the wall. **This is the most critical area to be sealed to assure a watertight installation.**
7. If the floor is concrete, drill through the Threshold Track's installation holes with a 1/4" masonry drill and insert plastic expanding anchors. Secure the Threshold Track using #10 x 2 1/2" flat-head screws into anchors. If the floor is wood, proper flashing must be installed prior to door installation. Where the screws penetrate flashing, pump sealant into holes prior to inserting screws to ensure a proper seal.

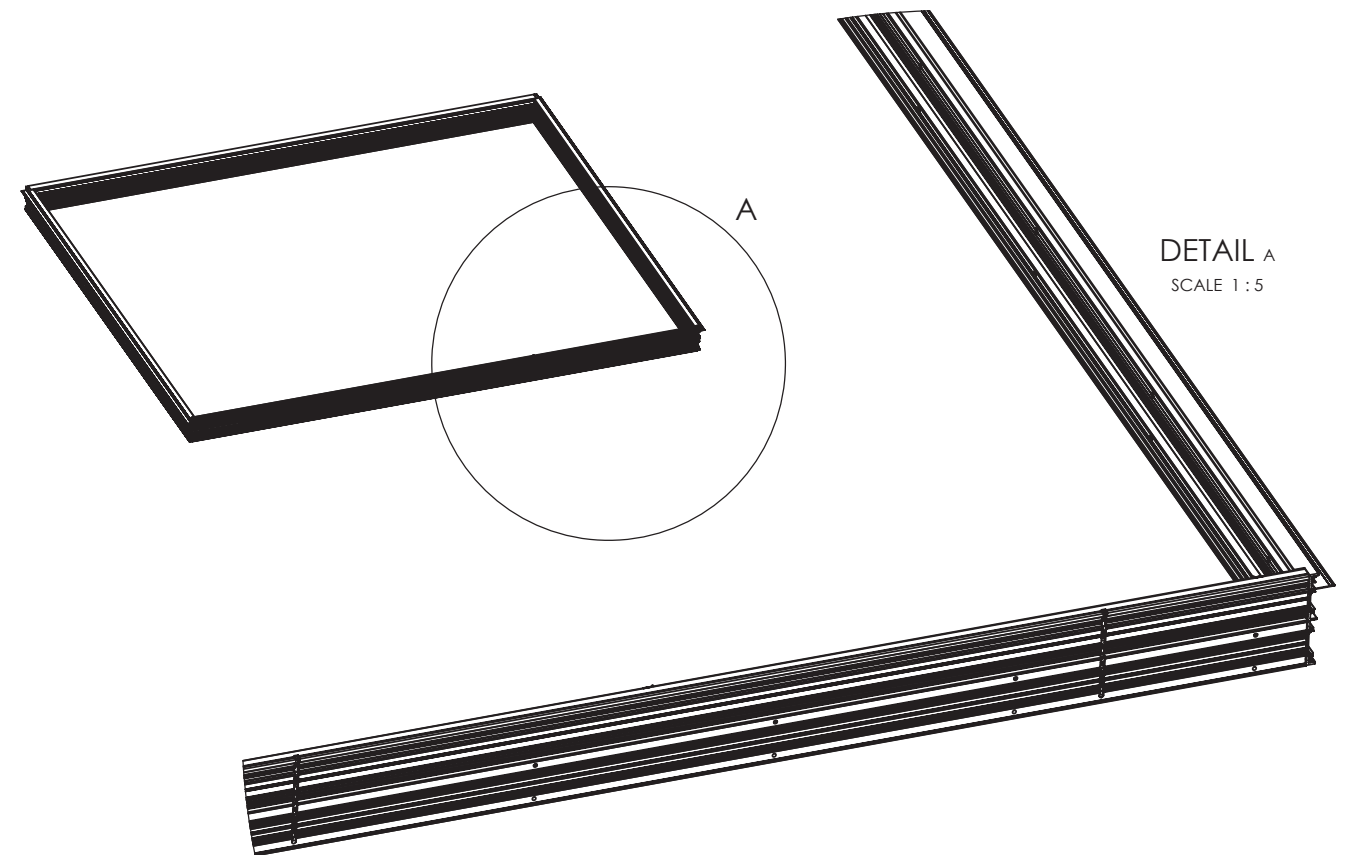
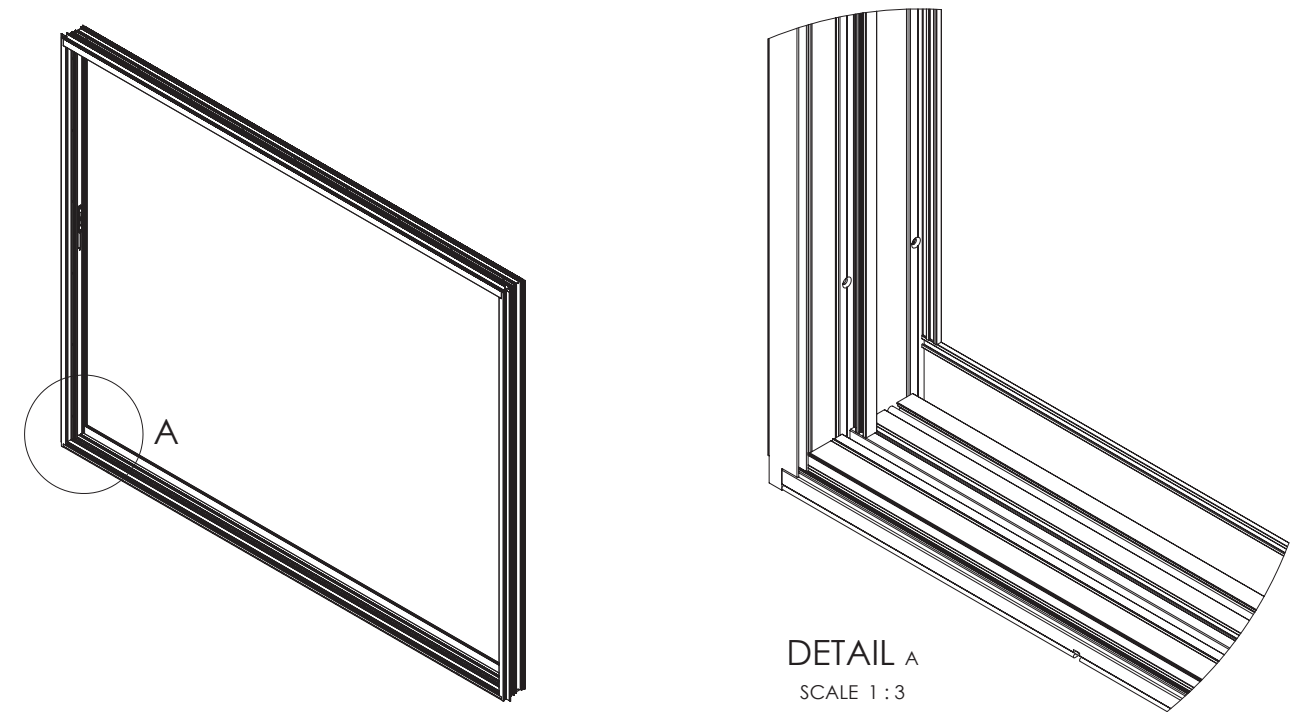

¹ Western Window Systems' preferred installation method is to anchor the threshold as described in these installation instructions. Alternatively, if installation is performed with un-anchored sill pans or sheet metal pans all the following requirements must be met: (1) the hard pan is shimmed flat and level prior to installation of the door; (2) the sill is set and sealed flat to the pan with no shimming in between or underneath the door threshold; (3) all applicable AAMA standards and building codes are met; and (4) the installation does not cause any product defect covered by Western Window Systems' limited express warranties. Failure to fully support the threshold by strictly complying with the described methods may cause property damage (including water intrusion) and injury and may also void Western Window Systems' limited express warranties.

- Plumb and square the Jambs using shims just above each installation anchor hole. At structure or wood framing, secure jambs with #10 x 2 1/2" flat-head screws. **If the Type 1 frame with integral nail fins is used, apply continuous corner bridges (supplied) then seal completely from the exterior side.**

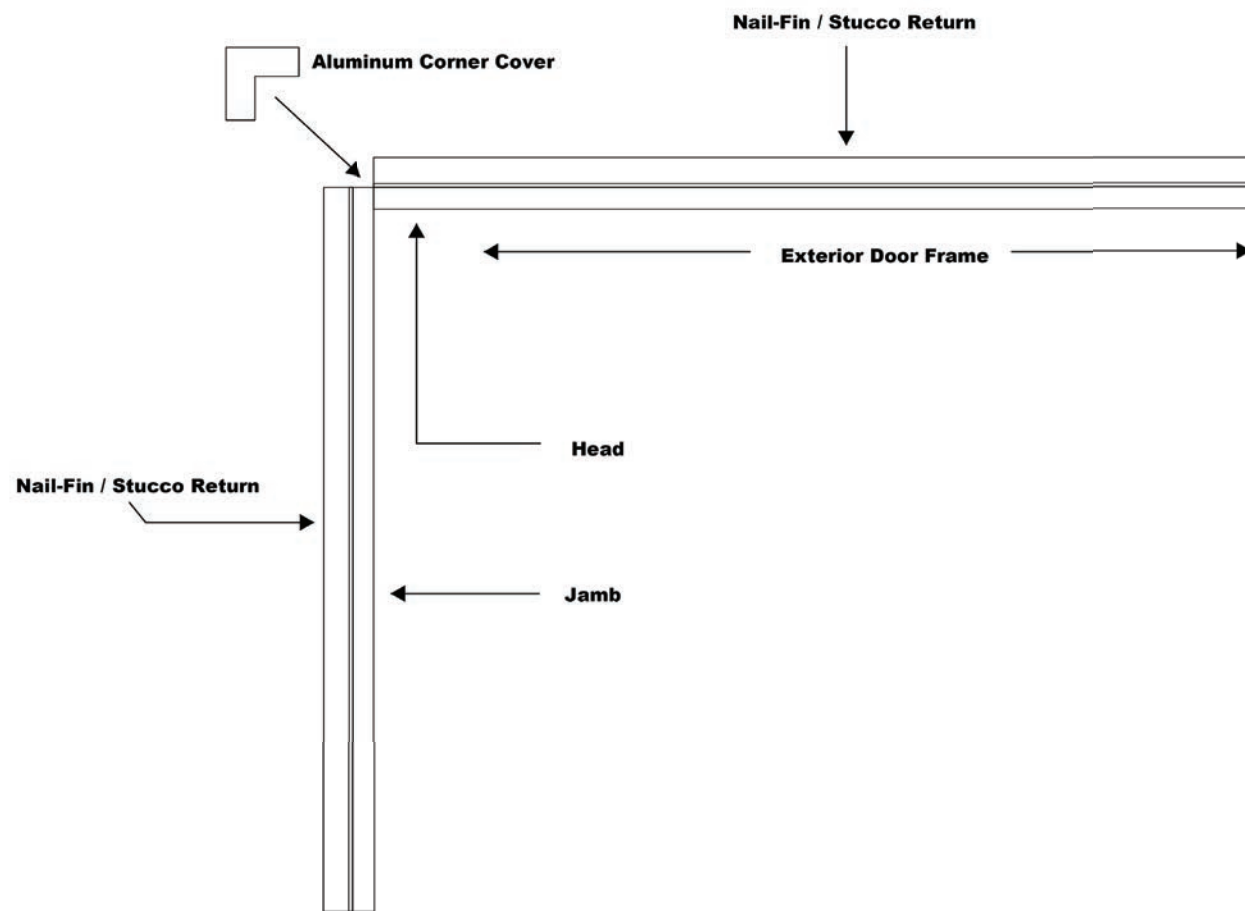

If you are installing a door that is bi-parting, there will be two Lead Panels. The Active Panel, the one that contains the lock mechanism, will be installed first on the left side of the inside track of the Head Track Assembly. Left panel active is the manufacturing standard. If the door has only one lead panel, it will be installed in the inside track of the Head Track Assembly on the appropriate side depending on the configuration of the door you are installing. From the outside of the building, with the glazing stop to the outside, lean the top of the panel in and insert it into the extreme interior head track and lower it onto the threshold.

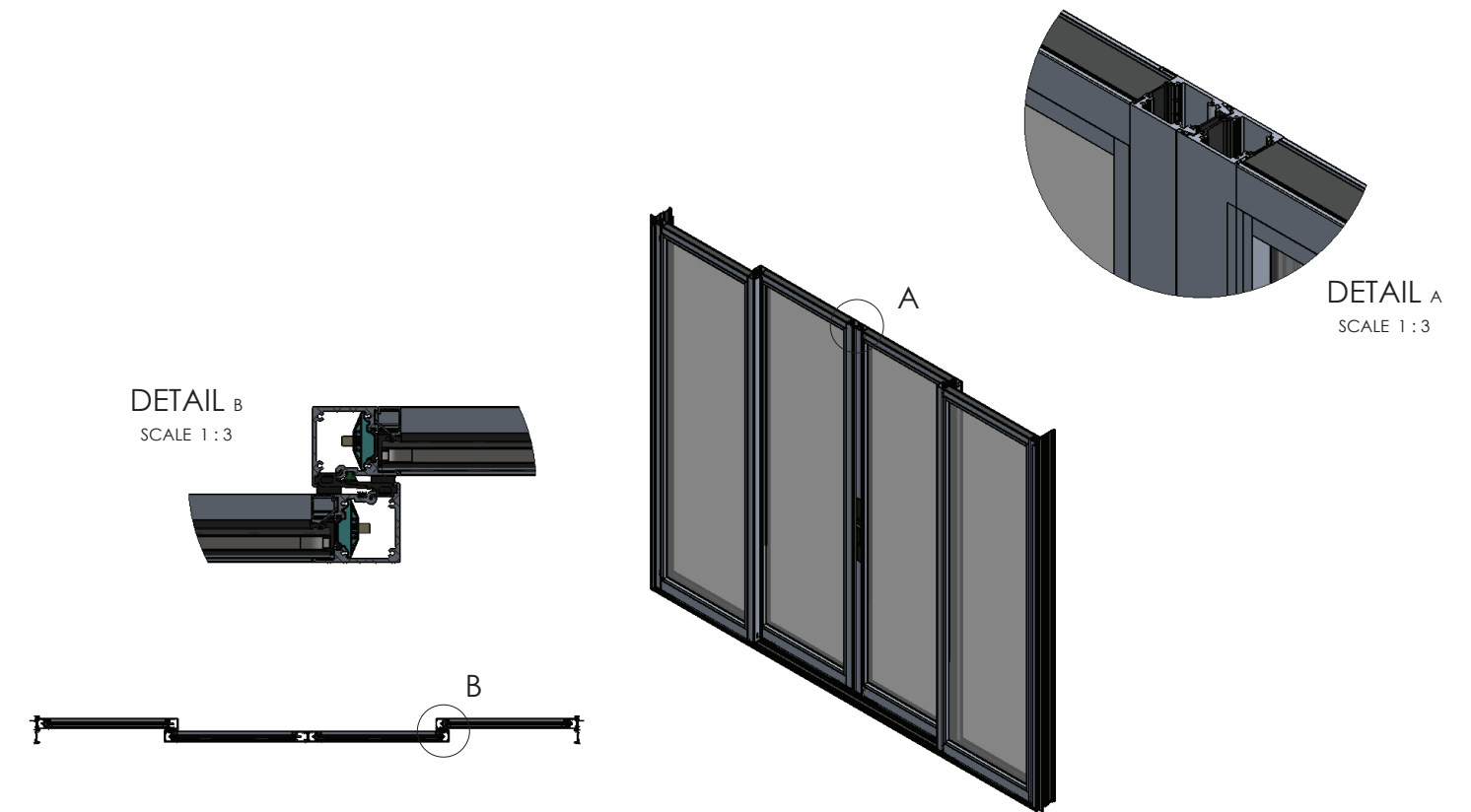

- Insert the Operating Panel into Head Track interior channel and lower onto the Threshold Track. Locate roller adjustment holes in the bottom of the Lock and Interlock Stiles. Lift weight off rollers and use a Phillips screwdriver to adjust each roller to accomplish a panel height of 5/16" between the Vent Bottom Rail and the Threshold Track. Make sure the Lock Stile is parallel to the jamb once adjustment is complete.
- Make final adjustment to the operable panel rollers to achieve the optimum alignment throughout the entire door. NOTE: The Fixed Panel does not have door rollers to align sight line horizontally.
- Insert Fixed Panel into Head Track exterior channel and lower onto the Threshold Track. With Operating Panel slightly open, use the ball of your foot to slide the Fixed Panel toward the fixed jamb and seat fixed stile into Jamb channel. Close and lock the Operating Panel. Fixed and Vent Interlock Stiles should engage and line up. If they do not, ensure frame and panels are plumb and square and that the Fixed Panel is fully seated in the Fixed Jamb Channel.
- From the interior, install #8 x 1 1/4" self-tapping oval head screws through the Fixed Jamb leg and into the Fixed Panel Stile. There should be a minimum of 3 through the top rail and a minimum of 4 down the jamb evenly spaced. The fixed panel set screws secure the fixed panel from being removed from the exterior.

13. Adjust the strike plate on the Lock Jamb by loosening the three machine screws and moving it up or down until the lock engages fully when actuated. To remove excessive slack, open the sliding panel and adjust the lock using the slotted adjusting screw in the center of the lock.
14. Seal the perimeter of the door frame to the structure with a quality construction sealant compatible with the flashing membrane you are using.
15. Door installation is complete.

Configuration: OXOL and OXOR doors only

1. Review your configuration and determine which side the Dead-Lite Fixed Panel will rest in your frame.
2. Insert the Dead-Lite Fixed Panel (a panel with no interlocking stiles) into Head Track exterior channel and lower onto Track Threshold.
3. Using the ball of your foot, slide the Dead-Lite Fixed Panel toward the fixed jamb and seat fixed stile into Jamb channel.
4. Install False Jamb member into frame by placing the top end into the Head Track channels and against the Dead-Lite Panel with the bottom end angled away from the panel.
5. Push up slightly to raise the door head. Avoid scratching the Fixed Threshold when moving the bottom end toward the panel.
6. Using the ball of your foot, slide the False Jamb toward the Dead-Lite Panel and seat onto Dead-lite fixed stile.
7. Shim the Head Track directly above the False Jamb until parallel with the Sill Threshold.
8. From the interior, anchor the Dead-Lite Panel to the Frame Head Track, Fixed Jamb and False Jamb using #8 x 1 1/4" self-tapping oval head screws through the frame assembly and into the Fixed Panel. There should be a minimum of 3 through the top rail and a minimum of 4 down each of the jambs evenly spaced. This screw secures the false jamb or fixed panel from being removed from the exterior. Install bumper stop into the head at the Fixed Jamb.

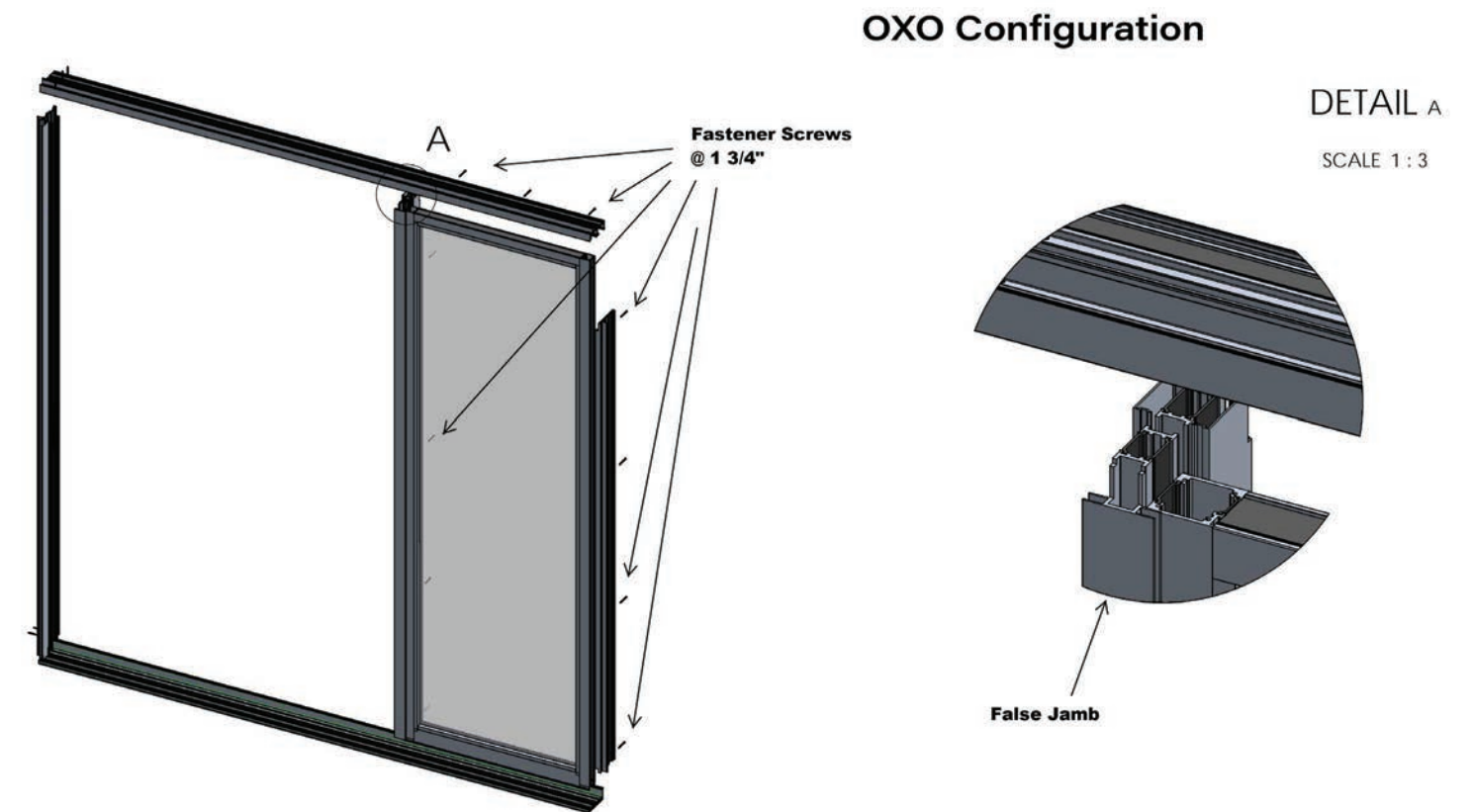

9. Using a plastic block and non-marring mallet, complete the Dead-Lite channel assembly by placing the Jamb Fillers onto the fixed jamb and false jamb, and lightly tap it into place.
10. Insert the Operating Panel into Head Track interior channel and lower onto the Threshold Track. Locate roller adjustment holes in the bottom of the Lock and Interlock Stiles. Lift weight off rollers and use a Phillips screwdriver to adjust each roller to accomplish a panel height of 5/16" between the Vent Bottom Rail and the Threshold Track. Make sure the Lock Stile is parallel to the jamb once adjustment is complete.
11. Make final adjustment to the operable panel rollers to achieve the optimum alignment throughout the entire door. **NOTE:** *The Fixed Panel does not have door rollers to align sight line horizontally.*
12. Insert Fixed Panel into Head Track exterior channel and lower onto the Threshold Track. With Operating Panel slightly open, use the ball of your foot to slide the Fixed Panel toward the fixed jamb and seat fixed stile into Jamb channel. Close and lock the Operating Panel. Fixed and Vent Interlock Stiles should engage and line up. If they do not, ensure frame and panels are plumb and square and that the Fixed Panel is fully seated in the Fixed Jamb Channel.

Configuration: XOO and OOX doors only

1. Review your configuration and determine which side the Dead-Lite Fixed Panel will rest in your frame.
2. Insert the Dead-Lite Fixed Panel (a panel with no interlocking stiles) into Head Track exterior channel and lower onto Track Threshold.
3. Using the ball of your foot, slide the Dead-Lite Fixed Panel toward the fixed jamb and seat fixed stile into Jamb channel.
4. Install False Jamb member into frame by placing the top end into the Head Track channels and against the Dead-Lite Panel with the bottom end angled away from the panel.
5. Push up slightly to raise the door head. Avoid scratching the Fixed Threshold when moving the bottom end toward the panel.
6. Using the ball of your foot, slide the False Jamb toward the Dead-Lite Panel and seat onto Dead-lite fixed stile.
7. Shim the Head Track directly above the False Jamb until parallel with the Sill Threshold.
8. From the interior, anchor the Dead-Lite Panel to the Frame Head Track, Fixed Jamb and False Jamb using #8 x 1 ¼" self-tapping oval head screws through the frame assembly and into the Fixed Panel. There should be a minimum of 3 through the top rail and a minimum of 4 down each of the jambs evenly spaced. This screw secures the false jamb or fixed panel from being removed from the exterior. Install bumper stop into the head at the Fixed Jamb.
9. Using a plastic block and non-marring mallet, complete the Dead-Lite channel assembly by placing the Jamb Fillers onto the fixed jamb and false jamb, and lightly tap it into place.
10. Insert the Operating Panel into Head Track interior channel and lower onto the Threshold Track. Locate roller adjustment holes in the bottom of the Lock and Interlock Stiles. Lift weight off rollers and use a Phillips screwdriver to adjust each roller to accomplish a panel height of 5/16" between the Vent Bottom Rail and the Threshold Track. Make sure the Lock Stile is parallel to the jamb once adjustment is complete.
11. Make final adjustment to the operable panel rollers to achieve the optimum alignment throughout the entire door. **NOTE:** The Fixed Panel does not have door rollers to align sight line horizontally.

XOO Configuration

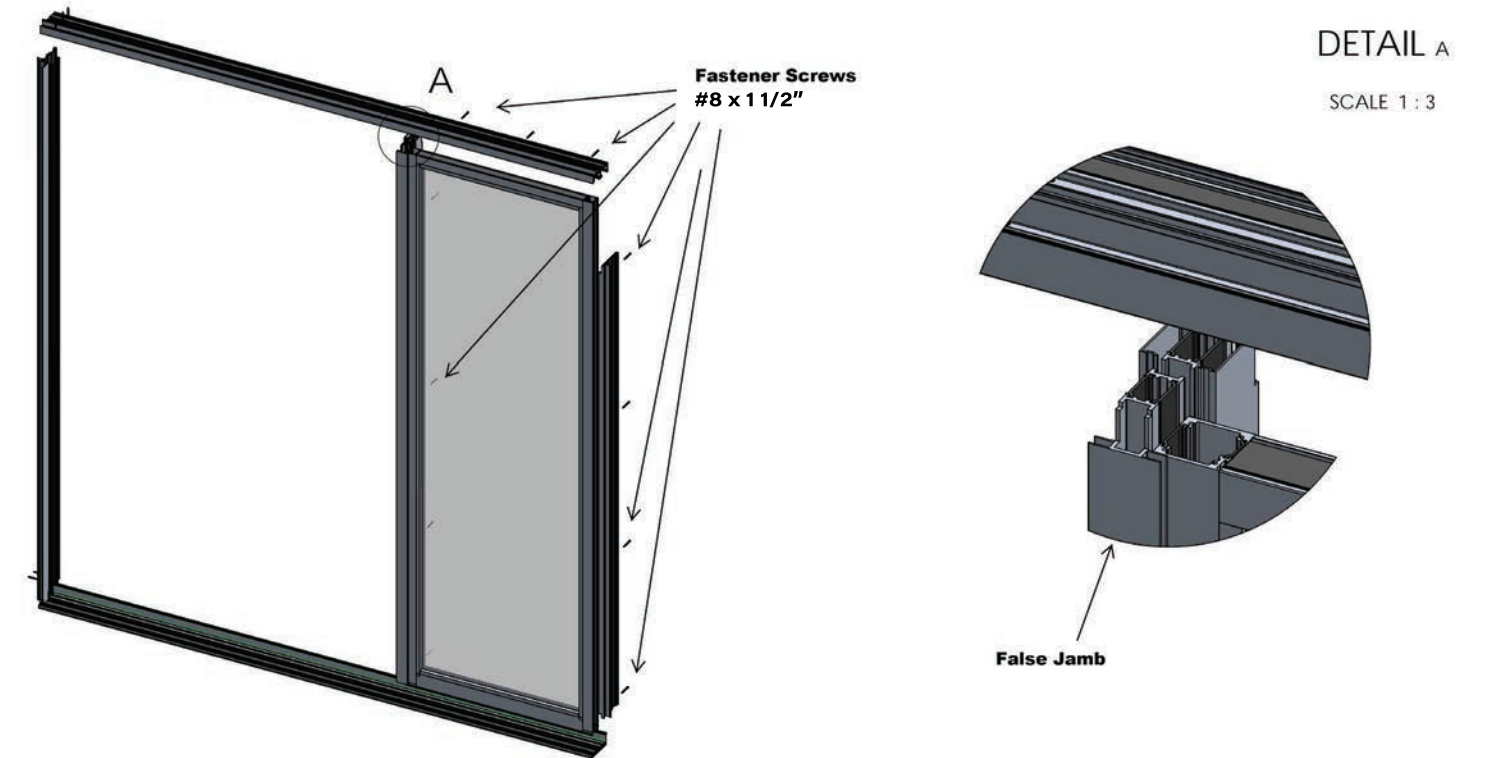

12. Insert Fixed Panel into Head Track exterior channel and lower onto the Threshold Track. With Operating Panel slightly open, use the ball of your foot to slide the Fixed Panel toward the fixed jamb and seat fixed stile into Jamb channel. Close and lock the Operating Panel. Fixed and Vent Interlock Stiles should engage and line up. If they do not, ensure frame and panels are plumb and square and that the Fixed Panel is fully seated in the Fixed Jamb Channel.
13. From the interior, install #8 x 1 ¼" self-tapping oval head screws through the Fixed Jamb leg and into the Fixed Panel Stile. There should be a minimum of 3 through the top rail and a minimum of 4 down the jamb evenly spaced. The fixed panel set screws secure the fixed panel from being removed from the exterior.
14. Adjust the strike plate on the False Jamb by loosening the three machine screws and moving it up or down until the lock engages fully when actuated. To remove excessive slack, open the sliding panel and adjust the lock using the slotted adjusting screw in the center of the lock.
15. Seal the perimeter of the door frame to the structure with a quality construction sealant compatible with the flashing membrane you are using.
16. Door installation is complete.

Screen Installation

1. Position screen in front of the door opening and on the outside of the building with the flat side toward the door and screen lock stile at the door lock jamb.
2. Lift the screen and insert the top edge into the outer track of the door head channel. Move the bottom toward the threshold until the rollers contact the roller track. Using a small flat pry bar, lift rollers, one at a time, onto the track.
3. Using a Phillips screwdriver, adjust two bottom rollers so the screen lock stile is parallel with the door jamb. When adjustments are complete, there should be a minimum of vertical movement when you attempt to move the screen up and down.
4. Using the screws provided with screen door, install screen strike onto door jamb at proper height to receive lock hook.



westernwindowssystem.com | 877-268-1300
2200 E. Riverview Dr., Phoenix, AZ 85034