

Series 600 Aluminum Multi-Slide Door

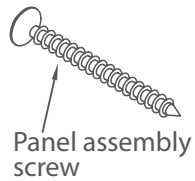

Premium Handle Bottom Rail Panel Bumper Stop: Set for Thermal Break

Hole locations are critical in avoiding damage to glass and hardware.



Lead stile

Bumper base

Bumper attachment screw

Bumper stop

Note: This bumper is used for multi-slide doors with premium handles.

Use template to locate mounting holes.

07/32" x 3/8"
Deep hole for pin

01/8" x 1.00"
Deep hole for screw attachment

Exterior

9/16" (0.5625")
1 25/32" (1.7812")
13/16" (0.8125")

Bottom rail

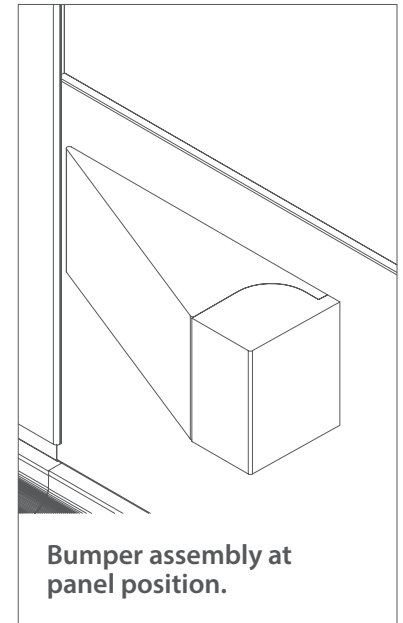

These drawings are for identification purposes only. Do not use for production runs.

Door Stop Templates



Series 600 Aluminum Multi-Slide Door

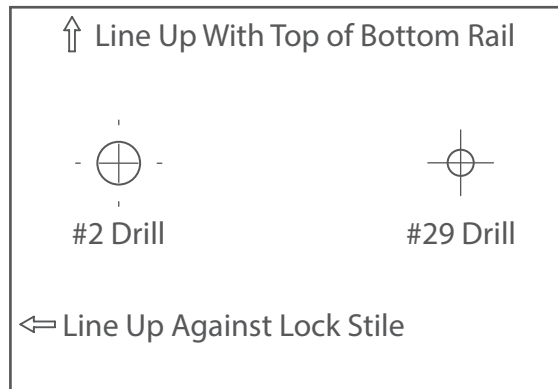

XO Configuration

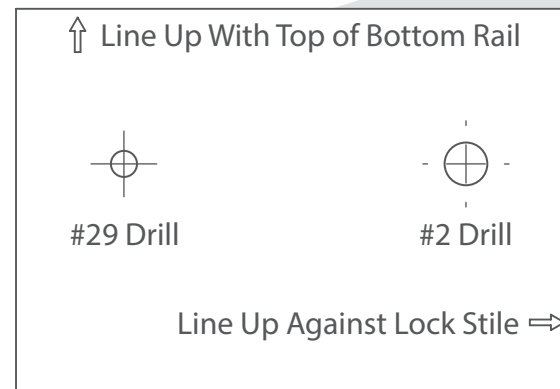

OX Configuration